



J.A. Becker & Söhne
Hydraulic Multi-Ram Lifts for
Commercial Vehicles



1897: Technical locksmithery

Approx. 1900: Production of machine spindles

Approx. 1920: Fruit and grape presses

Approx. 1930: Hydraulic lifts

Today: Competence in hydraulic lifting technology and industrial compressors

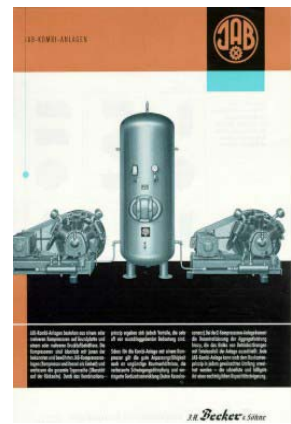
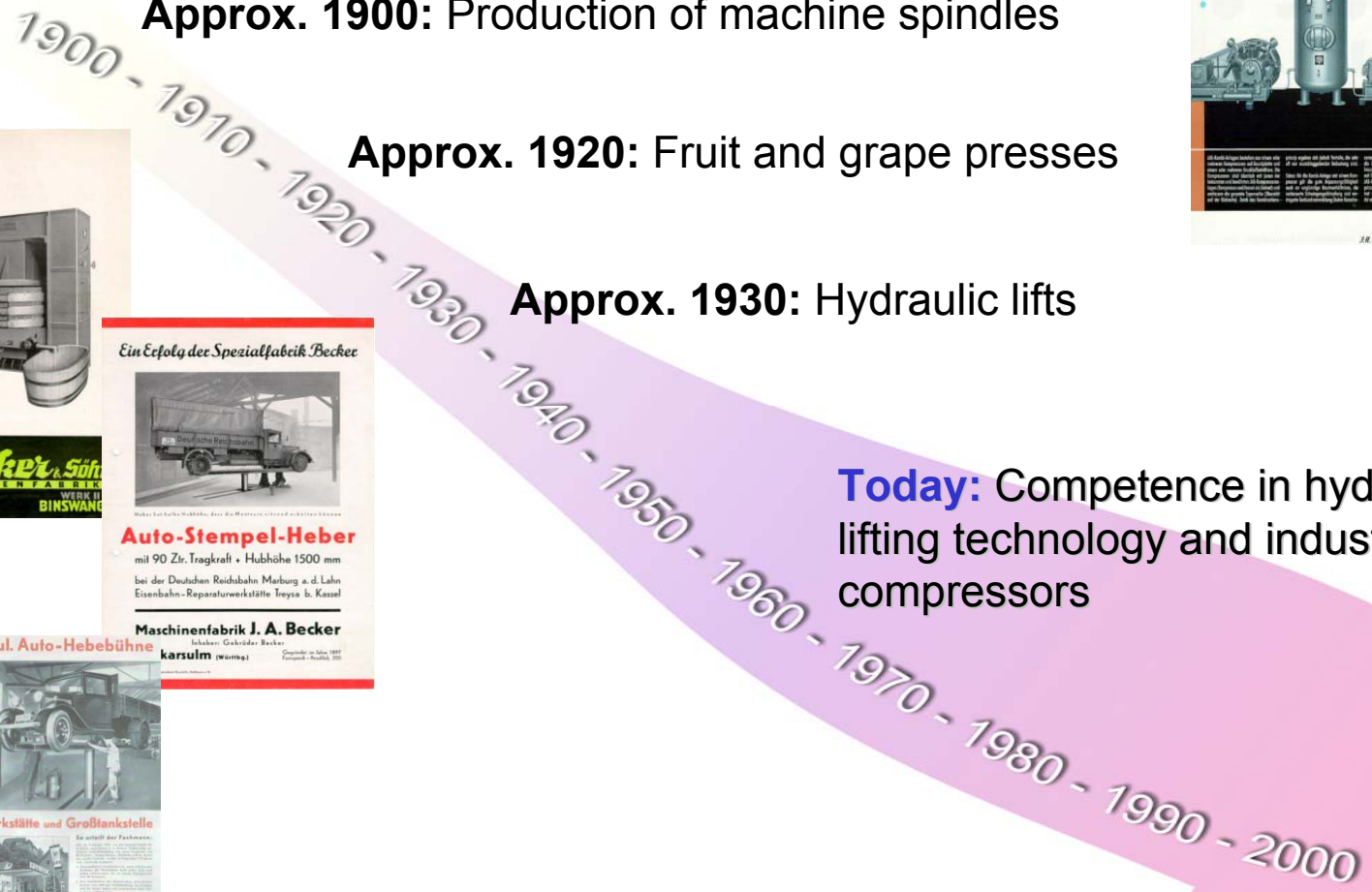

JAB- Eldest Lift Manufacturer in Europe



JAB – Overview

- Approx. 150 employees
- Specialised in lifting technology and compressors since more than 80 years

Lifting technology

- 60 % of annual turnover
- 32 sales partners worldwide

Compressors

- 40% of annual turnover
- 33 sales partners worldwide

- Export rate: approx. 64% over both product ranges



JAB LIFTING TECHNOLOGY



Passenger car lifts



Heavy duty lifts



J.A. Becker & Söhne



In our manufacturing program we have a wide range of lifts for....



Lifts for Industrial trucks



Lifts for tramways/streetcars and boggies



Bus lifts



Tank lifts



Electrical power supply



Natural gas filling stations

Our compressor units are used in several application fields...



Plastic injection molding



Nitrogen extraction



Bio-Methane-Compression



Breathing Air



Our sales partners worldwide

The world of
J.A. Becker & Söhne

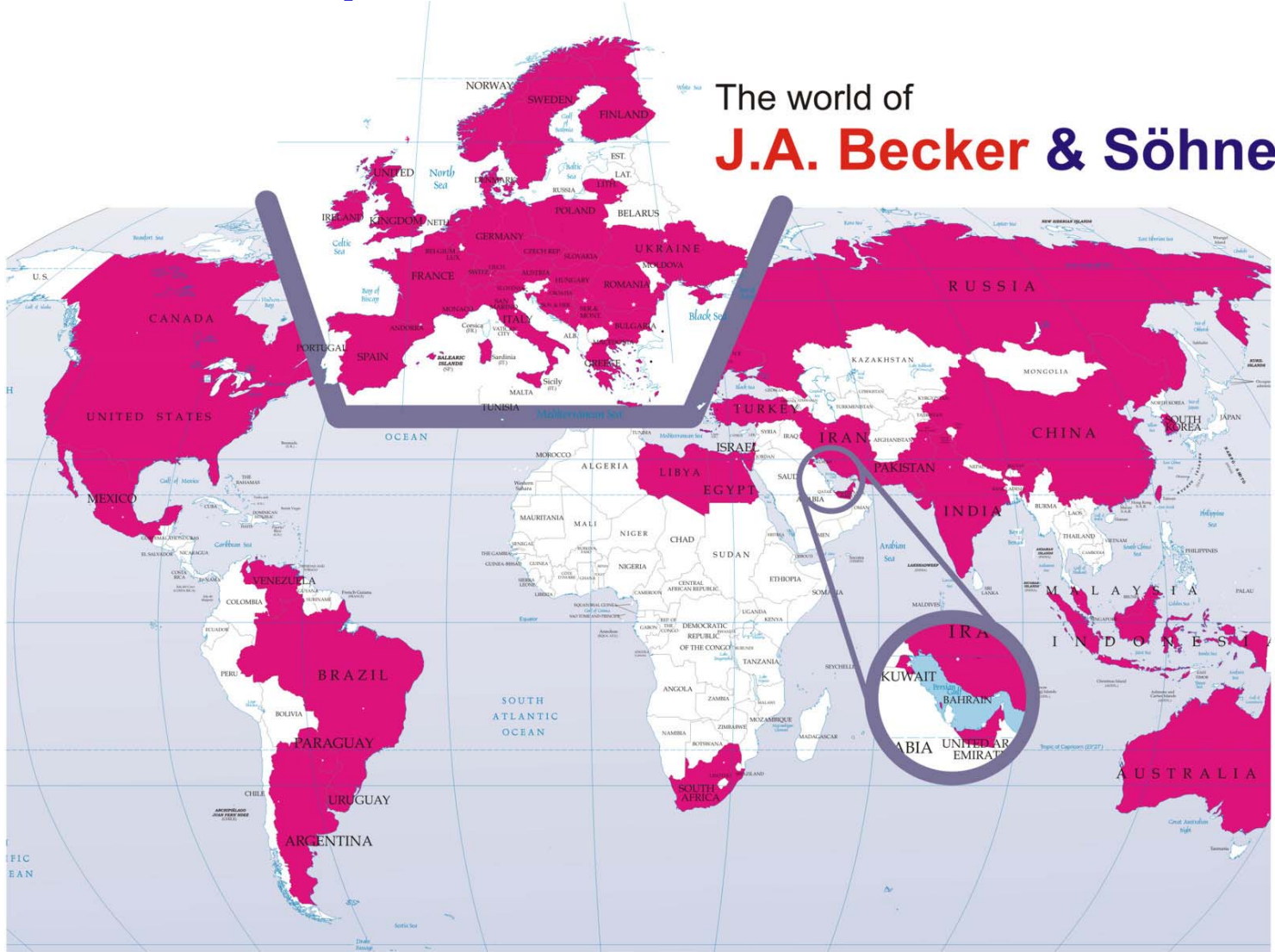



Inground Lifting Technology

Advantages and
disadvantages



Advantages and disadvantages of inground lifting technology

- **Advantages:**
 - Accessibility of vehicle : from all sides
 - Optimal lateral access for low platform buses
 - Wheel free accessible (tyre change, brake)
 - Fast wheel positioning through moveable ram(s)
 - Gain of time : fast lifting of vehicles
 - Gain of place : Workshop floor can be used much more flexible as with other lift types
- **Disadvantages:**
 - Ground excavation: Foundation necessary
 - Higher initial invest: Long-term investment; pay back in saved workshop lifting cycle time and reduced lift-service downtime
 - Fixed installation: Installation frame and cassette cannot be used again when moving into another building
 - Corrosion : only if corrosion protection is insufficient
 - High ground water level: Maybe telescopic rams to be used, installation depth only 1.500 mm



Product range

.. and technical data



Plunger-Version

Model MD 155-12

Lifting capacity: 12.000 kg per ram

Model MD 214

Lifting capacity: 16.000 kg per ram

Model MD 214-22

Lifting capacity: 22.000 kg per ram



Telescopic-Version

Model MD 214/190

Lifting capacity: 16.000 kg per ram

All types are available as 2-, 3-, 4-, 5- and Multi-ram lifting units



Technical Data

	MD 155-12 (Plunger)	MD 214 (Plunger)	MD 214-22 (Plunger)	MD 214/190 (Telescopic)
Nominal Capacity	12 t per ram	16 t per ram	22 t per ram	16 t per ram
Stroke	1.900 mm	1.900 mm	1.900 mm	1.900 mm
Piston-Ø	155 mm	214 mm	214 mm	214 / 190 mm
Nominal oil pressure	75 bar	47 bar	70 bar	57 bar
Moving range		3.750 mm (4.300 mm Deluxe)	3.750 mm (4.300 mm Deluxe)	3.750 mm (2.600 mm Deluxe)
Minimum installation depth	2.350 mm	2.350 mm (2.450 mm Deluxe)	2.350 mm (2.450 mm Deluxe)	1.450 mm (1.500 mm Deluxe)



2-Ram Lift

Type: HVZ 214

- Lifting capacity per ram: 16.000 kg
- Total lifting capacity: 32.000 kg
- Stroke: 1.900 mm
- Piston -ø: 214 mm
- Installation depth: 2.350 / 2.450 mm
- Moving range: 3.750 / 4.300 mm
- 1 ram fixed
- 1 ram moveable







2- Ram Lift

Type: HVZ 214/190 (telescopic rams)

- Lifting capacity per ram: 16.000 kg
- Total lifting capacity: 32.000 kg
- Stroke: 1.900 mm
- Piston-Ø: 214 / 190 mm
- Installation depth: 1.500 / 1.750 mm
- Moving range: 3.750 / 2.600 mm
- 1 ram fixed
- 1 ram moveable





2- Ram Lift

Type: HVZ 312 (Plunger) with doubled safety bars

- Lifting capacity per ram: 35.000 kg
- Total lifting capacity: 70.000 kg
- Stroke: 1.900 mm
- Piston-Ø: 312 mm
- Installation depth: 2.350 mm
- Moving range: 3.650 mm





2- Ram Lift

for industrial vehicles, Type: HGZ

Total lifting capacity:

- HGZ 5: 5.000 kg
(Piston-ø: 2x 50 mm)
- HGZ 5- Tele: 5.000 kg
(Piston-ø: 4x 130/ 90 mm)
- HGZ 8: 8.000 kg
(Piston-ø: 2x 155 mm)
- HGZ 12: 12.000 kg
(Piston-ø: 2x 214 mm)
- HGZ 15: 15.000 kg
(Piston-ø: 2x 214 mm)

All types:

- Stroke: 1.900 mm
- Installation depth: 2.400 mm
(HGZ 5: 2.430 mm
HGZ 5- Tele: 1.350 mm)





2- Ram Lift

for industrial vehicles, Type: Duo Ram HG 3 - MD 155/130 HG 3 Tele

Duo Ram HG 3:

- Lifting capacity: 3.000 kg
- Stroke: 1.900 mm
- Piston-ø: 2x 40 mm
- Guide bars-ø: 2x 90 mm
- Installation depth: 2.400 mm



Duo Ram HG 3

MD 155/130 HG 3 Tele:

- Lifting capacity: 3.000 kg
- Stroke: 1.900 mm
- Piston-ø: 155/ 130 mm
- Installation depth: 1.480 mm



MD 155/130 HG 3 Tele



3- Ram Lift

Type: HVD 214/190 (Telescopic rams)

- Lifting capacity per ram: 16.000 kg
- Total lifting capacity: 48.000 kg
- Stroke: 1.900 mm
- Piston-Ø: 214 / 190 mm
- Installation depth: 1.500 / 1.750 mm
- Moving range: 3.750 / 2.600 mm
- Ram 2 fixed
- Ram 1 and 3 moveable
- All 3 rams moveable upon request

Available as plunger version
HVD 214 with installation
depth of 2.350 / 2.450 mm as
well





Stadtwerke
Osnabrück

308

308

Stadtwerke Osnabrück



CITARO

VOS

Dieser Bus fährt mit Dieselmotoren

WALLEN OS

Arbeitsplatz 6/2



4- Ram Lift

Type: HVV 214/190 (Telescopic ram)

- Lifting capacity per ram: 16.000 kg
- Total lifting capacity: 64.000 kg
- Stroke: 1.900 mm
- Piston-Ø: 214 / 190 mm
- Installation depth: 1.500 / 1.750 mm
- Moving range: 3.750 / 2.600 mm
- 2 Rams fixed
- 2 Rams moveable

In Deluxe-version with aluminium segment rolling covers 1 ram fixed and 3 rams moveable!

Available as plunger version type HVV 214 with installation depth 2.350 / 2.450 mm





25

FLUGHAFEN ZÜRICH
BERUFSFEUERWEHR

Z8

28



4- Ram lift

Type: HVV 214

Suitable as 2x Two-Ram lift or
1x Three Ram or 1 x Four-Ram lift





Plunger or Telescopic?

Decision criteria



Plunger or Telescopic rams?

Crucial for that decision are the total costs of the project.

Plunger Execution:

- Min. necessary installation depth: 2.350 mm (for recessed head plates: 2.450 mm)
- Lifts need a concrete foundation. (optional the fixed ram can be installed into a steel cassette)
- Short, minimum ram distance possible (wheel base)
- Good price – performance - ratio



Telescopic Execution:

- Min. necessary installation depth: 1.500 mm even with recessed head plates (for track-solution: 1.750 mm.)
- Installation in concrete foundation or steel cassette
- Optimal for difficult installation conditions or high ground water level
- Optimal solution for installation in existing pits





Concrete foundation or self-containing steel cassette?

Decision criteria



Concrete foundation or self-containing cassette?

Concrete foundation:

- *Necessary* for plunger rams
- *Possible* for telescopic rams
- Normally easy to realize in new buildings
- Reduced lift price and transport costs (no big steel cassettes necessary)
- Water drainage easily possible



Self-containing steel cassettes:

- Only for telescopic rams
- Installation in existing pits possible
- For difficult installation conditions (e.g. high ground water level etc.)
- Pre-assembly of lift at JAB possible





Vehicle specific supports

Lifting supports for each
vehicle type



Additional supports

We offer a vast variety of supports:



Universal-supports



Differential-supports



**Supports for low-platform buses
with air suspension**

Passenger car swiveling arms

Supports for trailers



Universal supports



AUFNAHMESCHIEBER - UNISYSTEM
- NUTZFAHRZEUGE-
Klappschieber

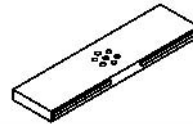

Planungsservice

J.A. BECKER & SÖHNE - 74148 NECKARSULM

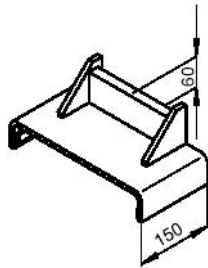

Bestell-Nr. 174647 *
Schmiedeachse
(vorne)

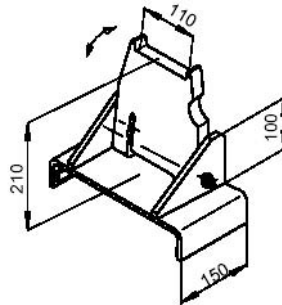

Bestell-Nr. 162879 / 162880 *

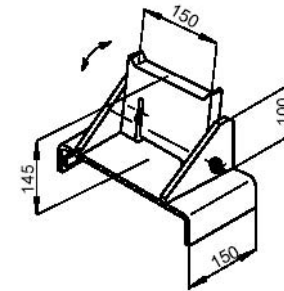

Bestell-Nr. 162886

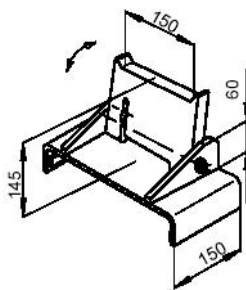

Bestell-Nr. 166390

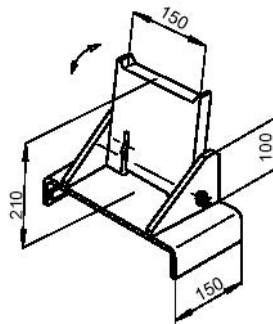

Bestell-Nr. 170907

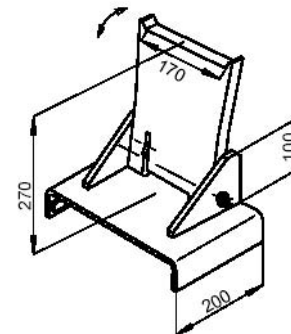

Bestell-Nr. 175784

* = Standardschieber



Universal supports





Differential-supports



AUFNAHMESCHIEBER - UNISYSTEM
- NUTZFAHRZEUGE -
Differential - Aufnahmeschieber



Planungsservice

J.A. BECKER & SÖHNE - 74148 NECKARSOLOM

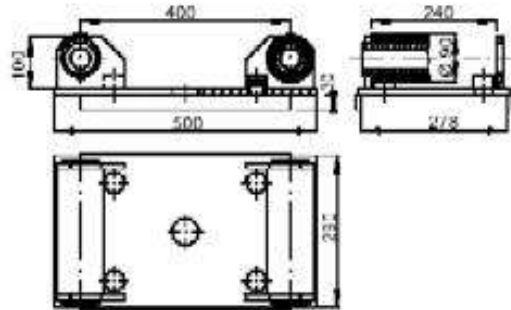

Bestell-Nr. 170358

für großes Differential
(Mercedes-Benz, MAN, u.ä.)

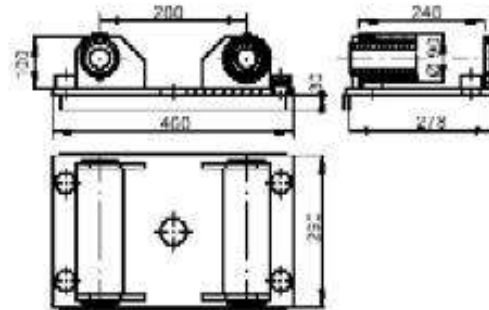

Bestell-Nr. 170360

für großes Differential
(VOLVO u.ä.)

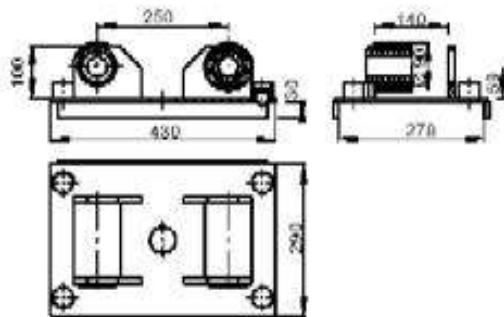

Bestell-Nr. 170359

für kleines Differential
(Mercedes u.ä.)



■ PU



Differential-supports





Supports for low-platform buses



**AUFNAHMESCHIEBER - UNISYSTEM
- OMNIBUSSE-**

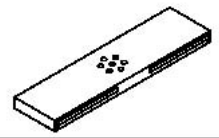

Planungsservice

J.A. BECKER & SÖHNE - 74148 NECKARSULM

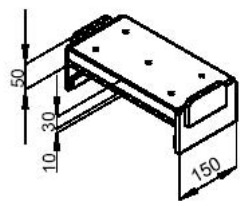

Bestell-Nr. 176631 *
Schmiedeachse oder
Wagenheberaufnahmepunkte
(vorne)

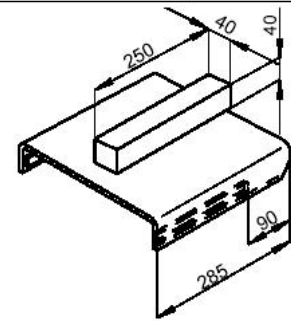

Bestell-Nr. 168742 *
Mercedes Benz und Setra - Buss
hinten
(unter dem Federträger)

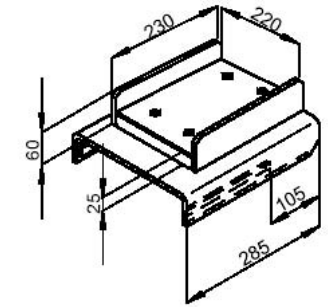

Bestell-Nr. 166335
ZF AV 132 - Achse
(hinten)

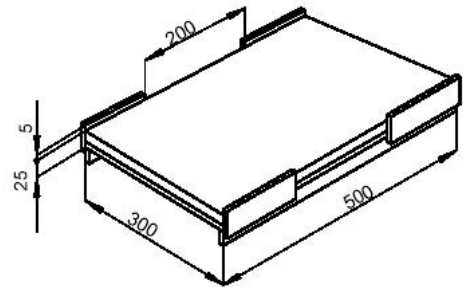

Bestell-Nr. 173723
Setra / Neoplan / MAN
(vor bzw. hinter der Vorderachse)

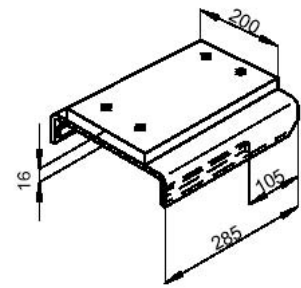

Bestell-Nr. 165376
MAN (hinten)

* = Standardschieber



Supports for low-platform buses

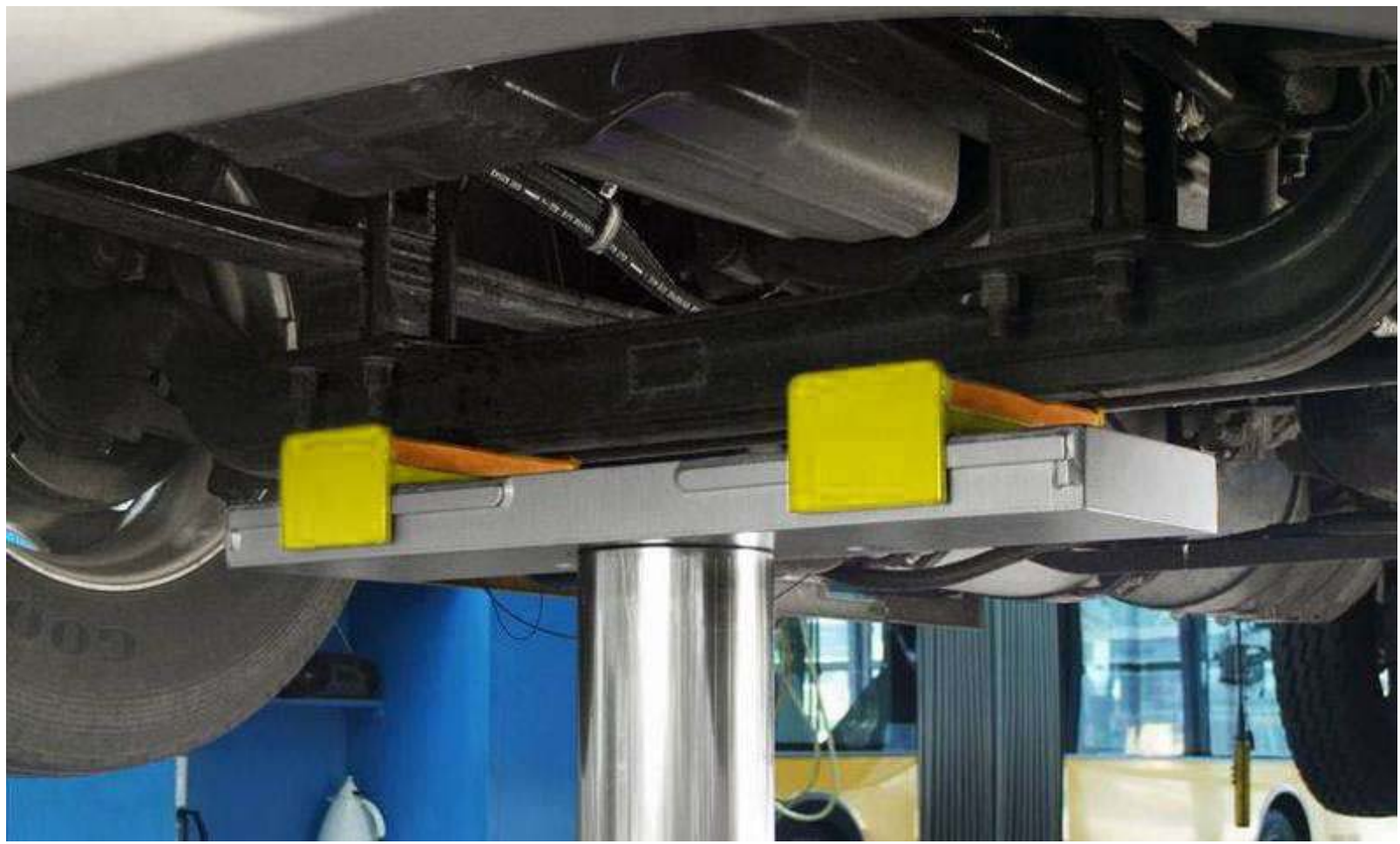



Passenger car swiveling arms



AUFNAHMESCHIBER - UNISYSTEM
- PKW - Zusatzaufnahme -

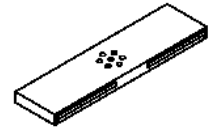

Planungsservice

J.A. BECKER & SÖHNE - 74148 NECKARSULM

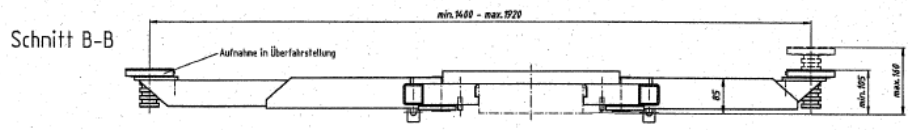

PKW -Zusatzaufnahme

Tragfähigkeit: 3000 kg

Bestell-Nr. 185115 (lackiert)

Bestell-Nr. 183837 (feuerverzinkt)

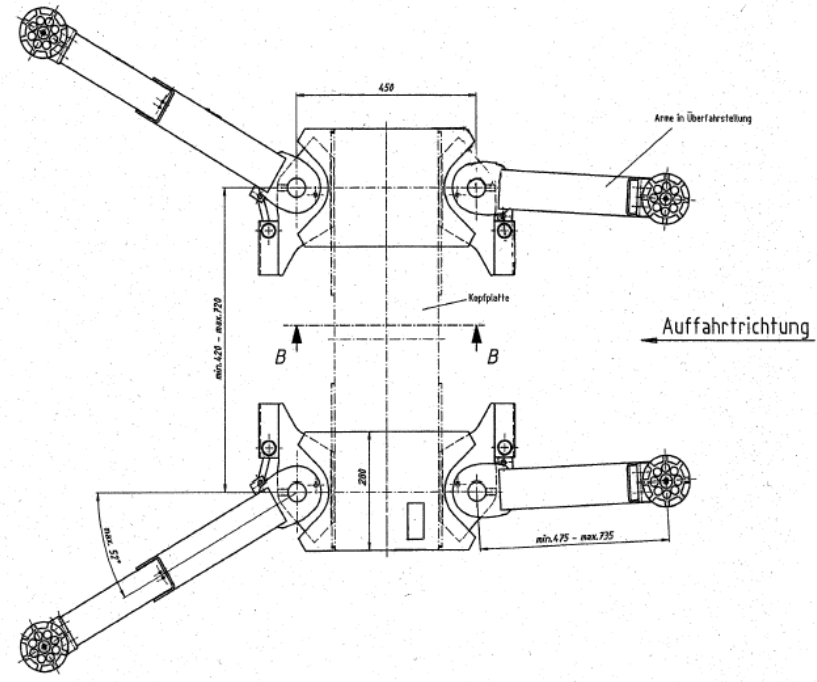



Supports for Trailers



**AUFNAHMESCHIEBER - UNISYSTEM
- NUTZFAHRZEUGE-
Sattelaufleger - Sonderschieber**

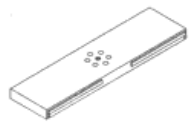

Planungsservice

J.A. BECKER & SÖHNE - 74148 NECKARSULM

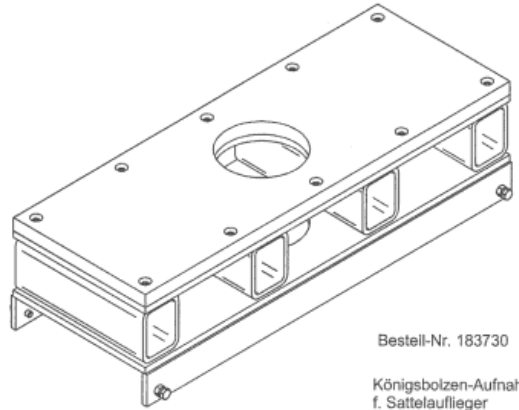

Bestell-Nr. 183730

Königsbolzen-Aufnahme
f. Sattelaufleger

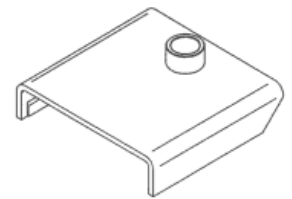

Bestell-Nr. 188002

Aufnahmeschieber
f. SLIFT - Stecksystm



Additional supports





Workshop carrier for additional supports

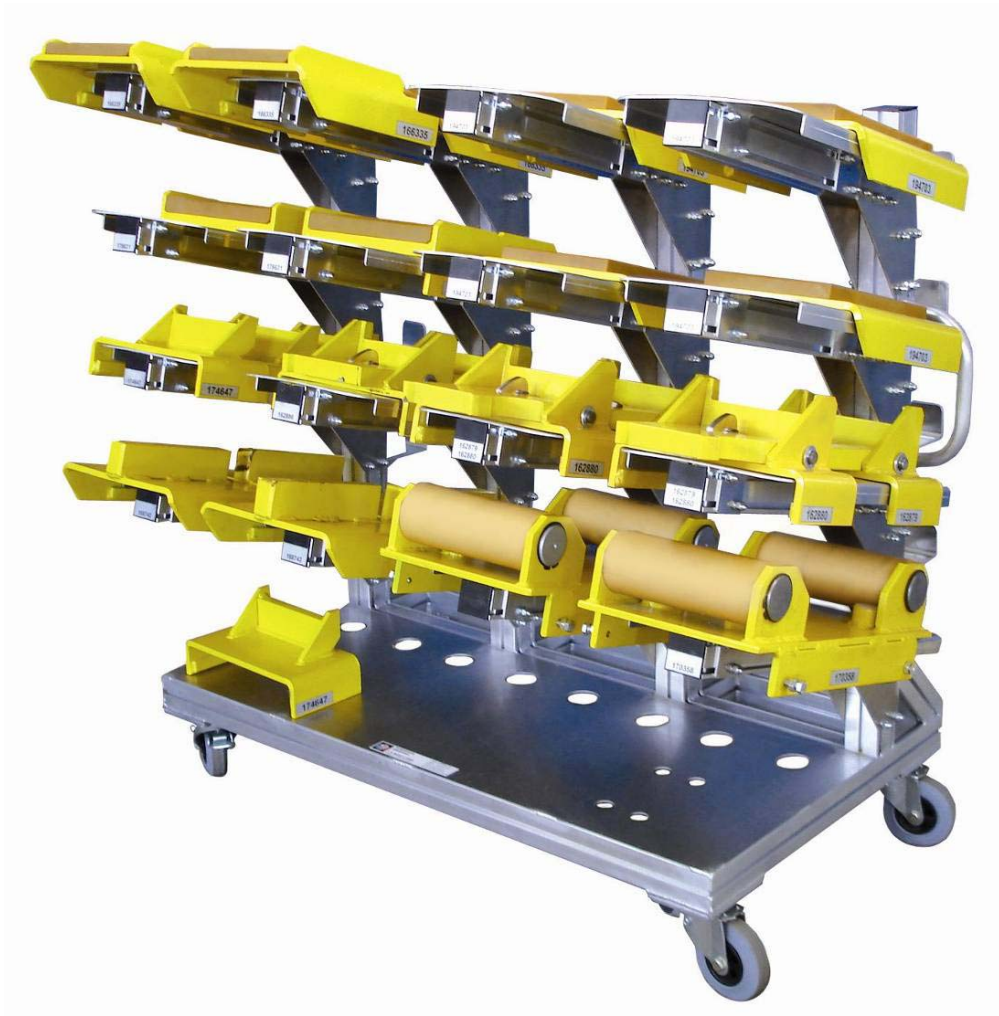



Standard execution

JAB Standard



Standard-Execution

	Type	Fixed ram	Moveable ram
2-Ram lift	HVZ	1	1
3-Ram lift	HVD	1	2
4-Ram lift BT/WT	HVV	2	2
4-Ram Lift Deluxe	HVV	1	3



Chromium plated pistons

Standard at JAB

- **Chromium plated pistons with excellent resistance against corrosion and wear**
- **Surface is much harder and smoother**
 - Higher durability of sealings, bearings and of piston.

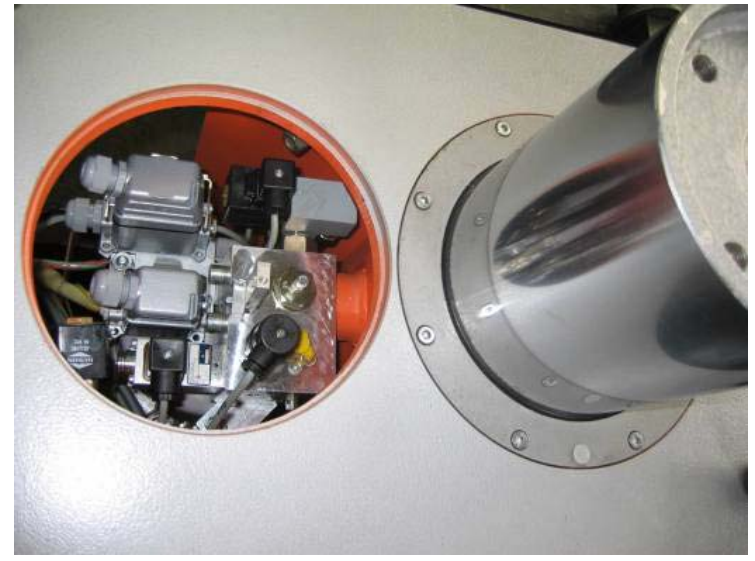



Telescopic sliding plates

- Max. wheel load: 3.000 kg
- Standard moving range: 3.750 mm

Pit or cassette is covered over complete Range of displacement

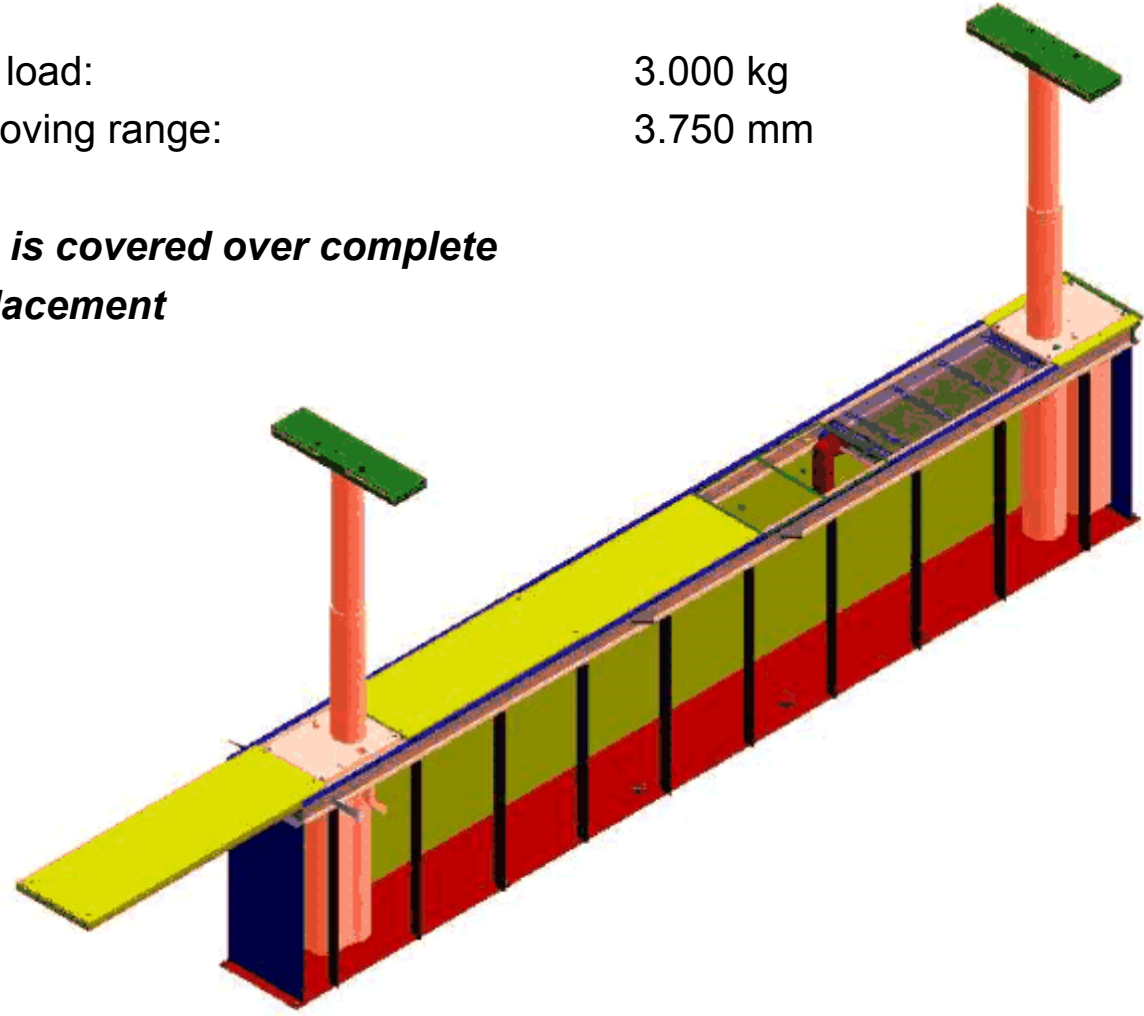



Aluminum segment roller plates

- Max. wheel load: 5.000 kg
- Standard moving range for plunger version: 4.300 mm
- Standard moving range for telescopic version: 2.600 mm

Pit or cassette is covered over complete range of displacement

Covering flush with the floor, no risk of stumbling

In recessed version also head plate flush with the floor!

Smallest minimum distance between two rams





Aluminum segment roller plates

Version 1

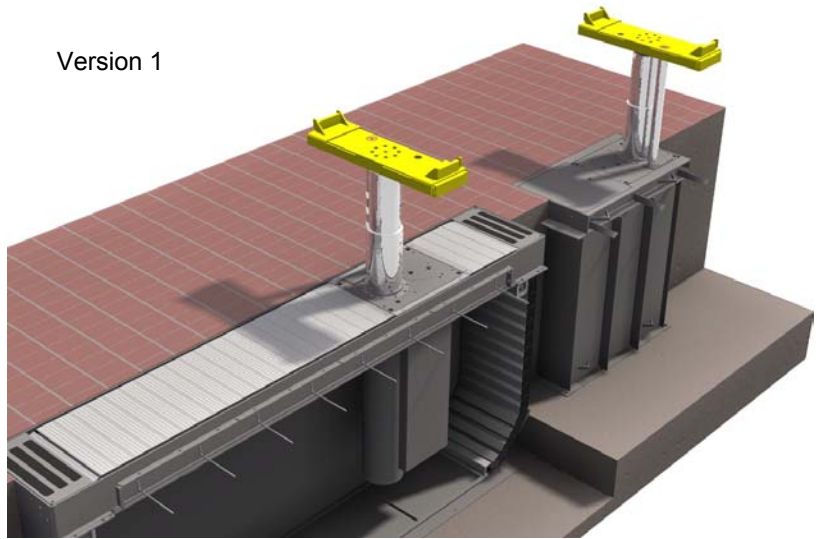

3 executions available:

- 1) Standard version with normal head plates
- 2) Recessed head plates
- 3) Fully recessed

Version 3

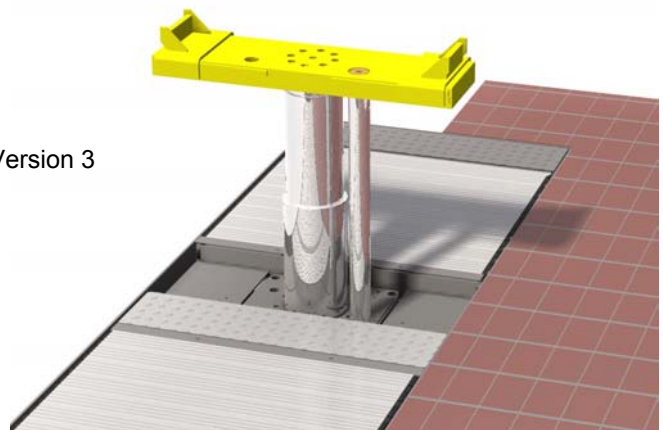

Version 2

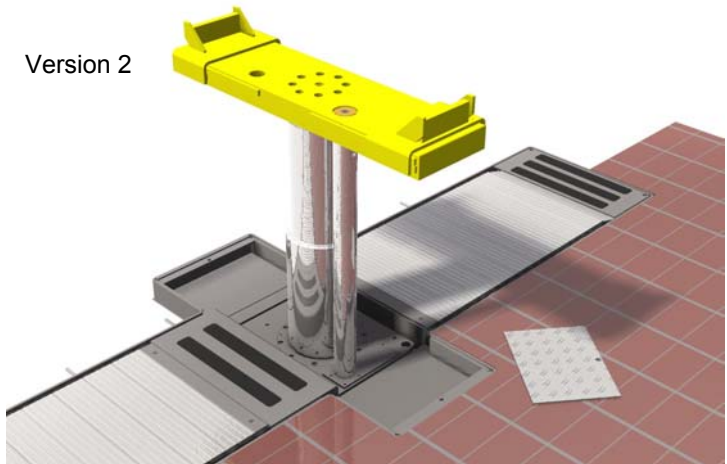



Aluminum segment roller plates

- aluminum hollow sections connected with reinforced thermoplastic connecting parts
- extremely corrosion-resistant
- resistant to saline solution (road salt)
- resistant to fuel, oil, weak acid and weak leach
- capacity up to 5 to wheel load for inflated tires
- capacity up to 3 to wheel load for full-cushion tires (fork lift)
- spare parts easy to replace – no hardware or glue needed

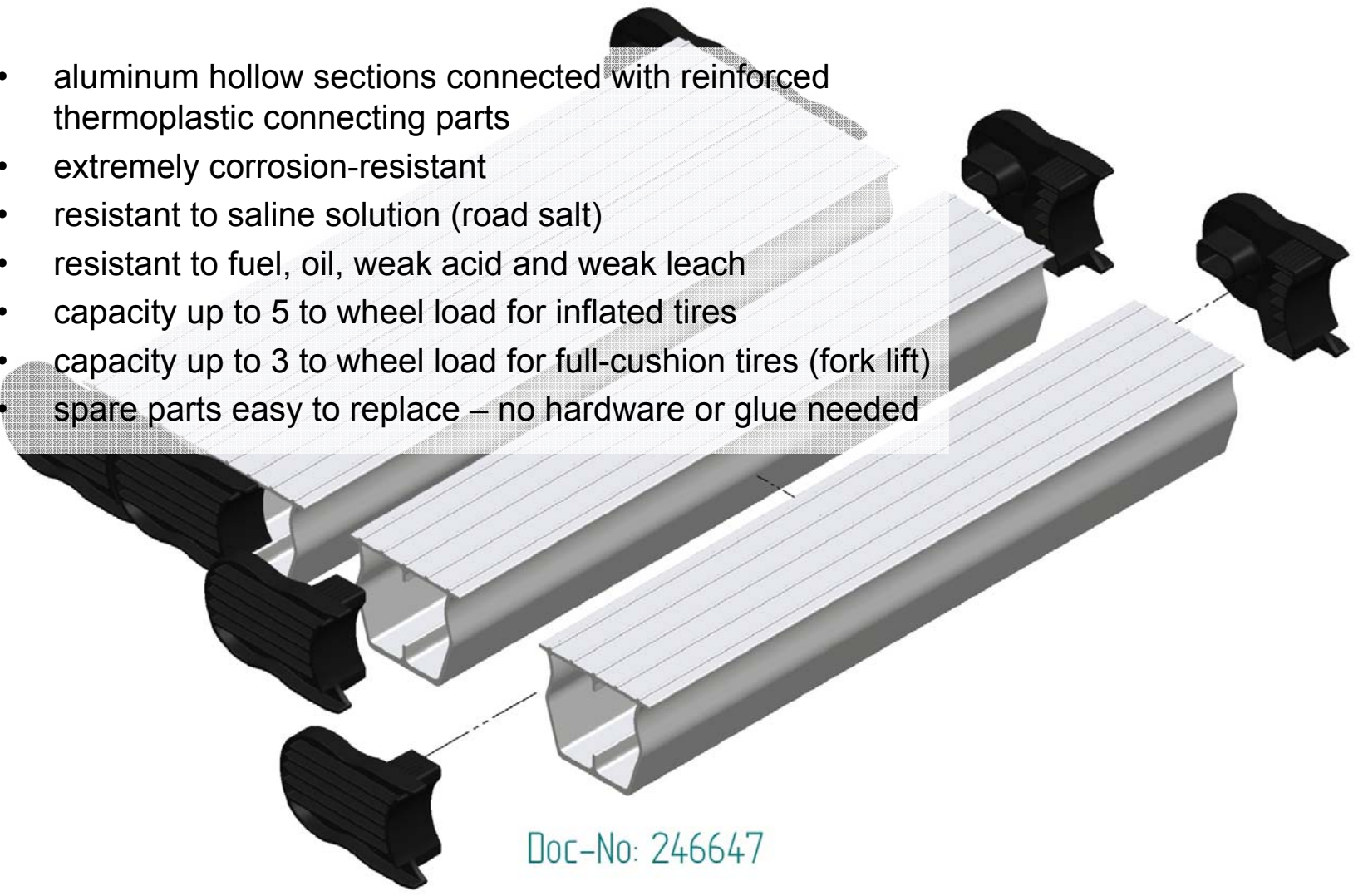

Doc-No: 246647



Quick and easy installation

Delivery



Installation – Step 1



Installation – Step 2



Ready- to- operate



Fail-safe with dirt (e.g. sand, gravel etc.)

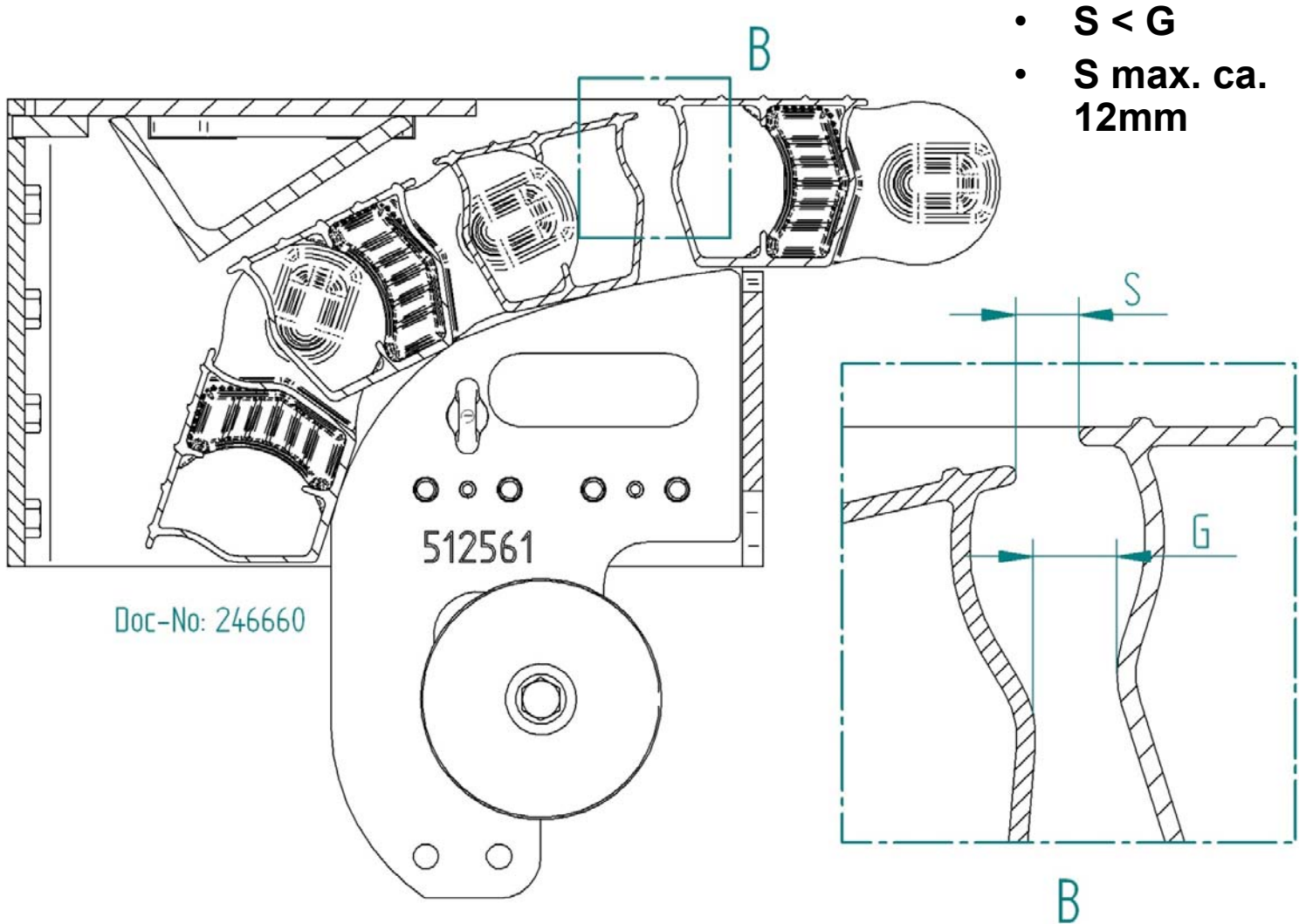



New standard range of horizontal travel with looped segment covering

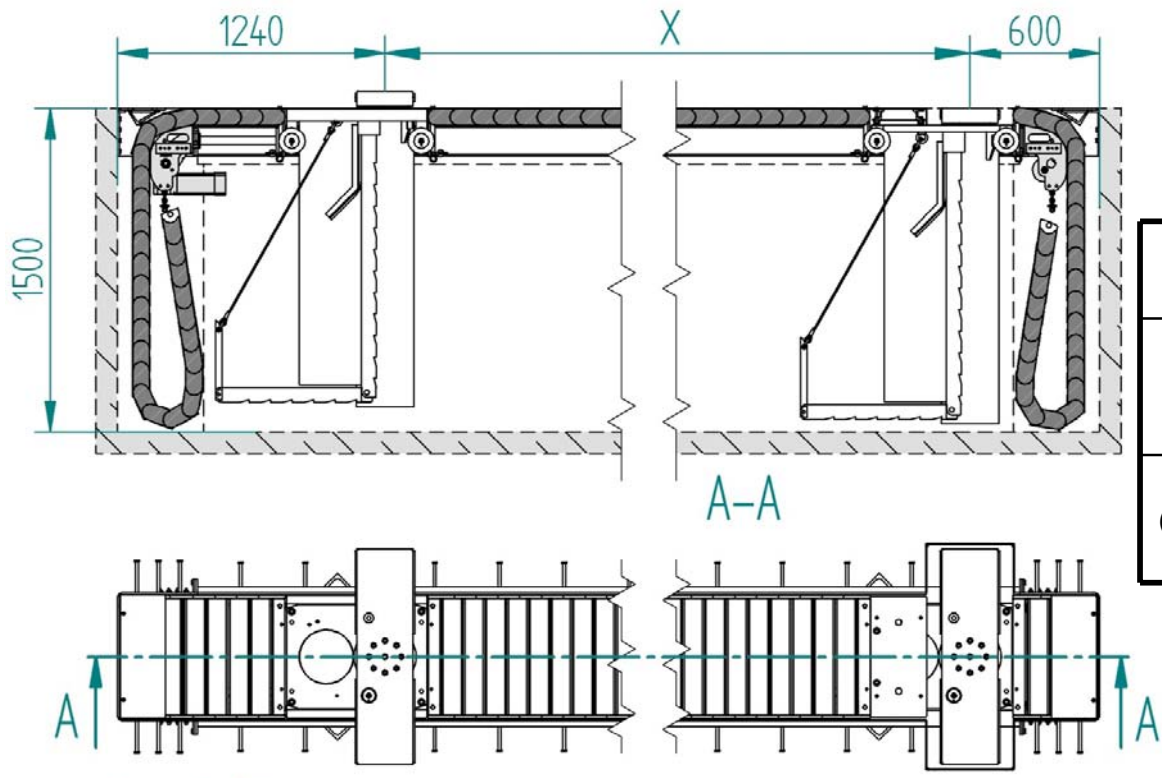

type of cylinder	X (mm)	foundation depth (mm)
214 (plunger cylinder)	4300	2450
214/190 (telescopic cylinder)	2600	1500

Doc-No: 246518



also possible bigger range of horizontal travel with track segment covering

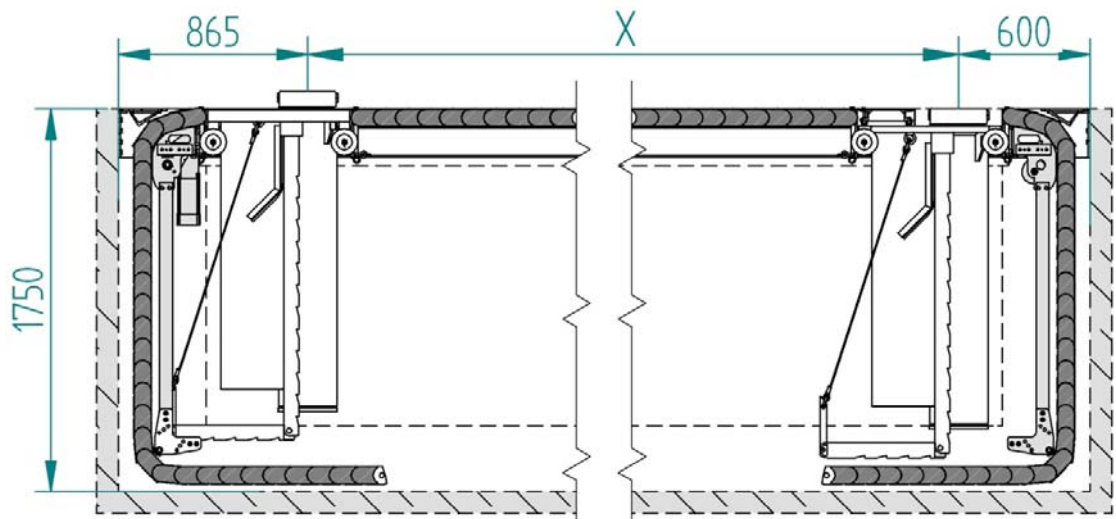

A-A

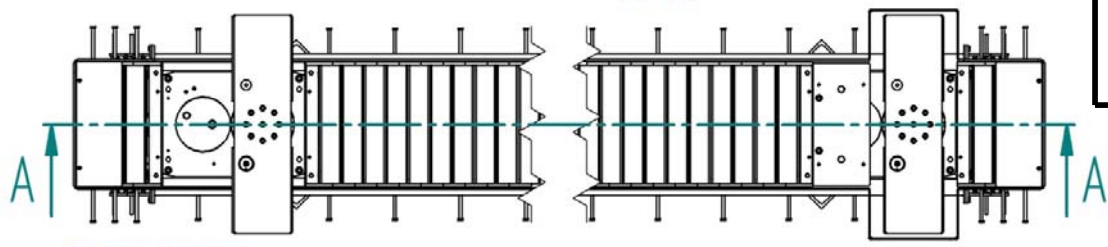

Doc-No: 246542

type of cylinder	X (mm)	foundation depth (mm)
214 (plunger cylinder)	7000 max.	2700
214/190 (telescopic cylinder)	7000 max.	1750



Controller MCU - Duo

- Performance

- Combination of rams

- ⇒ split HVS (6-ram lift) into 3x HVZ (2-ram lift) or 2x HVD (3-ram lift)
 - ⇒ synchronize button instead of “mode of operation” - switch
 - ⇒ selection of operation mode is simplified



- AWBP

- ⇒ selection by switch or display (optional)
 - ⇒ 15 storage locations for each ram combination
 - ⇒ increased precision

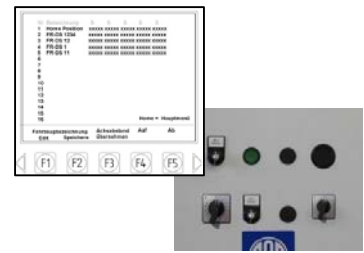

- Safety features

- ⇒ 2 channel emergency stop relay





Controller MCU - Duo

- remote maintenance (only in combination with display and TCP/IP-connection)
- lifting limit
 - ⇒ by external light barrier
 - ⇒ by programmable height limit

• Control box

- standardized control box size from HVZ through HVS
- standardized switch layout on the front of the control box
- LED – clamps / terminals



• New oil level sensor



• EMC – tested (electro – magnetic – compatibility)





Excellent system technology

Standard at JAB

2-, 3- and 4- ram lifts:

- **Synchronous run – electronically controlled**
 - Completely closed system, mounted inside of oil tank
 - Synchronisation accuracy within 50 mm of difference
 - The lift is stopped automatically in case there occurs a height difference of more than 100 mm during synchronous movement.
- **Automatic height balance of vehicle axles**
 - During vehicle “Set-Up” the rams drive in position by use of power sensors. At approx. 1.500 kg the rams stop – operator then switches to synchronous drive of all rams
 - Different height of axles or supporting points are thus balanced automatically
- **Lowering through reverse operating hydraulic pumps**
 - Lowering movement absolutely independent from load
 - Continual lowering speed *also without load*



Standard at JAB

- Motor, pump unit and valve block mounted inside a completely closed oil tank.
- Electronic synchronism device also assembled inside the oil tank
- **Optional** JAB offers all lifts in explosion proof version as well



Valve block directly flange at cylinder

Motor

Pump



Standard at JAB

- **Valve blocks directly flanged to cylinder**
 - No hydraulic tubes
 - No hydraulic pipes
 - No hydraulic couplings
- **In case of any leakage, oil flows into the...**
 - ... Oil tank!***





Standard at JAB

- Easy to maintain and repair through direct accessibility to ram sealings and hydraulic pump unit

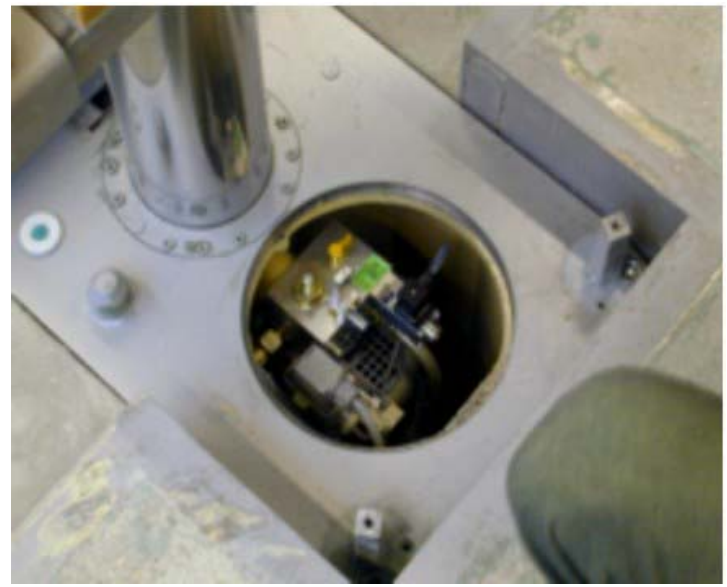
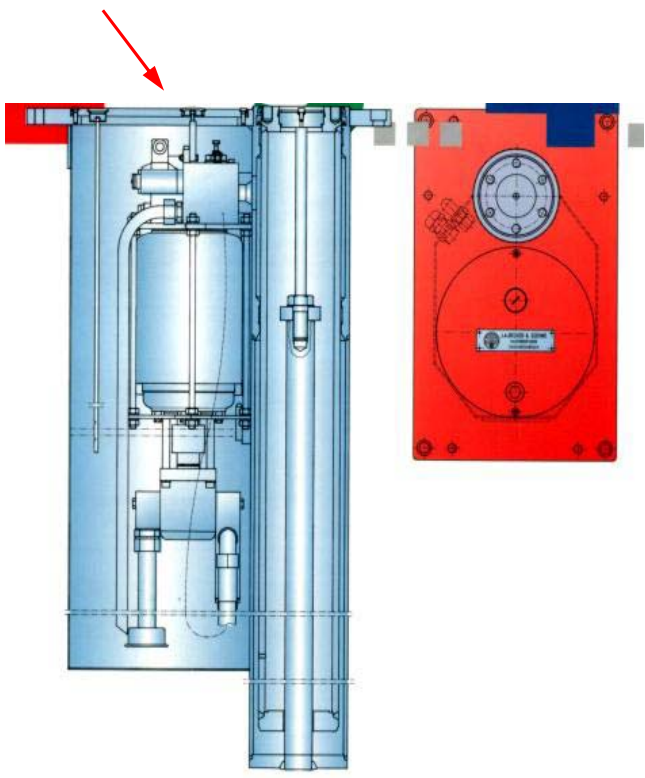



Manual emergency lowering

Standard at JAB

- **Simple to reach:** Manual emergency lowering in case of disturbance (e.g. power failure)
- **Easy to operate:** Emergency lowering outside vehicle outline

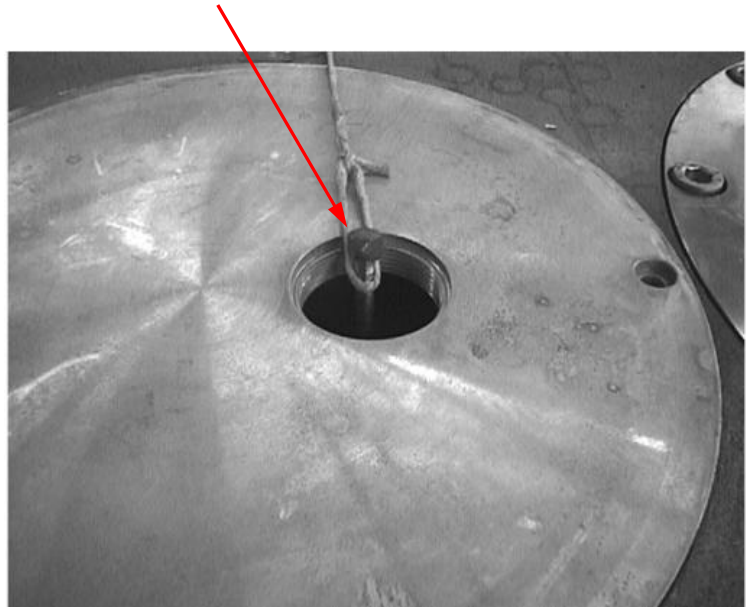



Optional Equipment

Additional accessories



Safety locking bars (mandatory in EU!!)

- Safety locking bars made out of solid material for highest demands
- Locking position at every 100 mm
- First engaged position is reached at a stroke of 300 mm
- Mechanical locking by springs, hydraulic unlocking
 - Automatically engaging



Telescopic ram:

Safety bar with hinge allows use in low pits or cassettes.





Safety locking bar

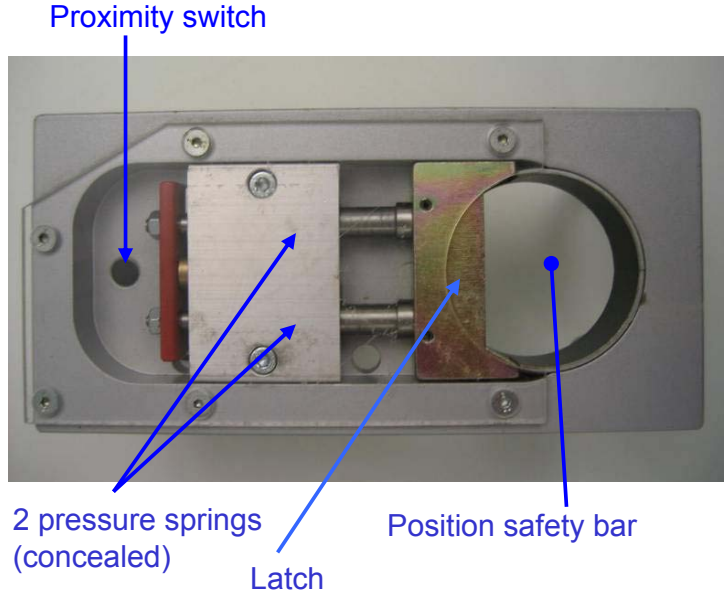

- Automatic locking
- Controlled hydraulic unlocking

Function during lifting movement:

- Two independent pressure springs hold the latch against the safety bar.
- Engaging of bar is audible.

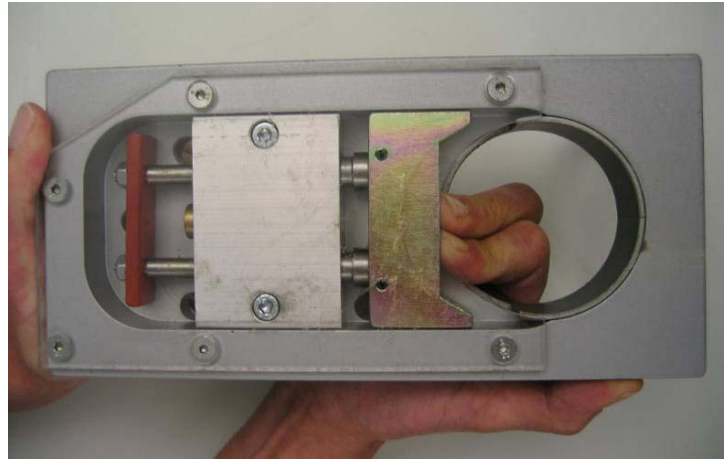

Function during lowering movement:

- The hydraulic pump starts and creates pressure, lock valve opens, latch retracts
- When the proximity switch detects the locks in fully opened position, lowering valves are released and lift lowers.



Recessed head pieces

- **Advantages:**
 - No risk of stumbling at park position / home pocket
 - Easy vehicle manoeuvring across shop floor





- **PHS – Programmable Height Setting**
Max. 4 different height limits can be stored
- **AWBP – Automatic wheel base positioning**
 - Up to 15 different wheel bases can be stored
 - Time saving at vehicle “Set-Up”



- **GPS – Optical indication for lowest position**

- Prevents damages during driving on and off in case lift is not lowered totally
- Indication driving on and off through red/green lights
- **Red** → Lift not in lowest position → **Do not drive on/off!!**
- **Green** → Lift in lowest position → **Drive on/off allowed!!**



Red/green lights



Proximity switch

Corrosion protection

- **Cassettes and/or rams coated with „Icosit-Poxicolor“**
 - “Icosit”-coating protects against electrolysis (corrosion)
 - “Icosit” = Two-component epoxy-coating
 - Excellent corrosion protection
- **Water sensor indicates fluid in the cassette via light signal in the control cabinet**



“Icosit“ coated cassette



“Icosit“ coated lifting unit



J.A. Becker Arguments

- JAB offers lifts with capacity of 8.000 up to 35.000 kg per ram
- JAB units are available with 2, 3, 4, 5 and 6 rams – upon request even more!
- JAB manufactures plunger and telescopic rams
- JAB Standard stroke is 1.900 mm
- JAB uses hard chromium plated pistons only
- Durni-Coat® 571 safety bars are standard
- Mechanical locking starts below 300 mm stroke
- Motor, pump and valve block are installed inside the oil tank
- Individual valve blocks are installed directly at the cylinder
 - No hydraulic hoses or tubing outside the oil tank
 - Excellent, environmentally sound technology



J.A. Becker Arguments

- Controlled electronic synchronisation device, optimally protected inside the oil tank!
- Automatic height setting of different vehicles axles – using pressure sensors
- Segment cover plates suitable for wheel pressure up to 5.000 kg
- Standard execution with cable remote control (optionally wireless)
- JAB offers an extensive range of accessories and options



Our customers...



Special projects



6- Ram lift

Inclusive safety bars and wheel centering

- Lifting capacity per ram: 6.000 kg
- Total lifting capacity: 36.000 kg
- Stroke: 1.900 mm

Higher capacities possible!





Bus Paint Shop

ATEX conform





Bus Lift





4-Ram Lift

Inclusive safety bars

- Lifting capacity: 70.000 kg

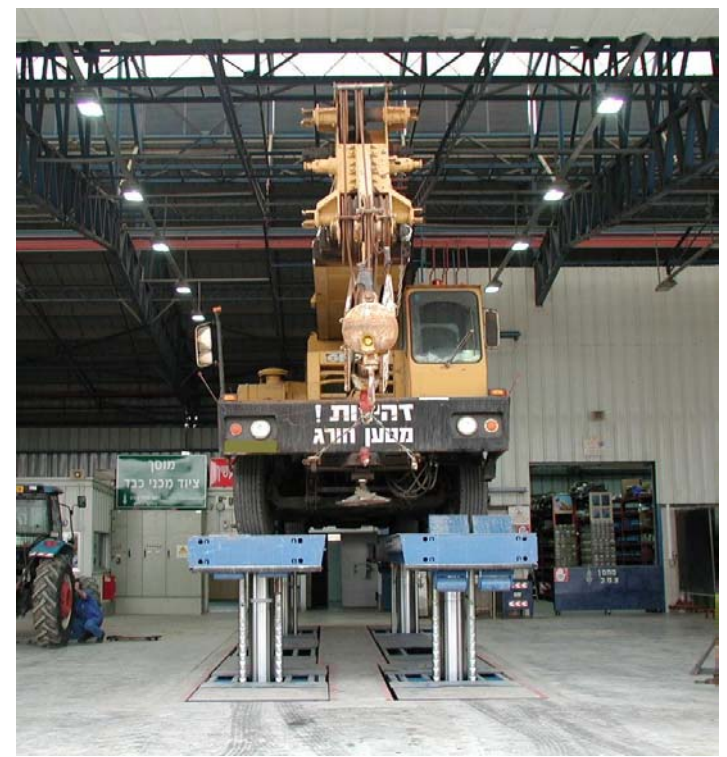



Tramway lifting units





Tramway lifting units

Bremen





Tramway lifting units



Nantes





Many thanks for your attention!

For further information, please feel free
to contact us.

J.A. Becker & Söhne
Postfach 1151
D-74148 Neckarsulm

Tel.: +49-(0)7132-367-0
Fax: +49-(0)7132-367-287
info@jab-becker.de
www.jab-becker.de